

# SINGLE USE MOLDED MANIFOLDS

## FOR BATCH FILLING & SAMPLING APPLICATIONS



Single use molded manifolds are custom made to meet your batch filling and sampling needs in drug and vaccine production.

Molded manifolds, manufactured from platinum-cured **Class VI** silicone, eliminate the need for barbed fittings while providing a seamless transition from tubing to connection for a continuous, unrestricted, leak-proof flow. Designs range from simple molded sanitary ends to complex configurations with varying lengths of tubing and several molded connections.

Single Use Molded Manifolds are not intended for implantation or continuous steam applications.



### KEY FEATURES

- Eliminates entrapment issues and leaks associated with barbed fittings
- Custom manufactured with Y's, T's, crosses, reducers, mini and standard Tri-Clamps®, stoppers and other container closures, and tubing
- Components are permanently molded into one, single-use manifold
- Provides a smooth inner surface without seams or crevices for even, uninterrupted flow
- One **animal-derived-ingredient-free** material contact surface throughout the assembly
- Reduces end-user component inventory and assembly labor time and expense
- Single use reduces the risk of cross contamination
- Also reduces downtime by eliminating certain cleaning validation requirements
- Provides flexibility in facility design—changes are less costly than with hard piping
- Sterilizable by autoclave and gamma radiation
- Retains silicone's wide range of temperature resistance: -100°F to 400°F
- Imparts no taste or odor to critical streams
- Manufactured and packaged in a **Class 7 (Class 10,000) ISO-certified clean room**
- Documented lot traceable with identification on bags
- Documented quality control
- Experienced engineers available for technical assistance
- DocuLink™ (patent pending) manifold assembly identification permanently molds a part number and/or lot number onto a manifold for quick visual reference and to track the part back to its origins (see back page)
- Optional RFID tags easily attach to assemblies for identification purposes providing reliable electronic data storage and current status of assemblies from inception to disposal



SILICONE

[www.advantapure.com](http://www.advantapure.com)

# SINGLE USE MOLDED MANIFOLDS

FOR BATCH FILLING & SAMPLING APPLICATIONS

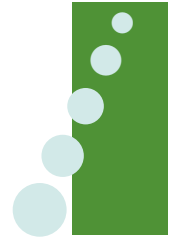

An AdvantaPure Single Use Molded Manifold is a complete unit, packaged in a sealed polybag and ready for use. Leaks, entrapment, and contamination concerns involved with barbed fitting connections are eliminated. Labor, numerous inventories, and time to assemble the manifold are unnecessary.

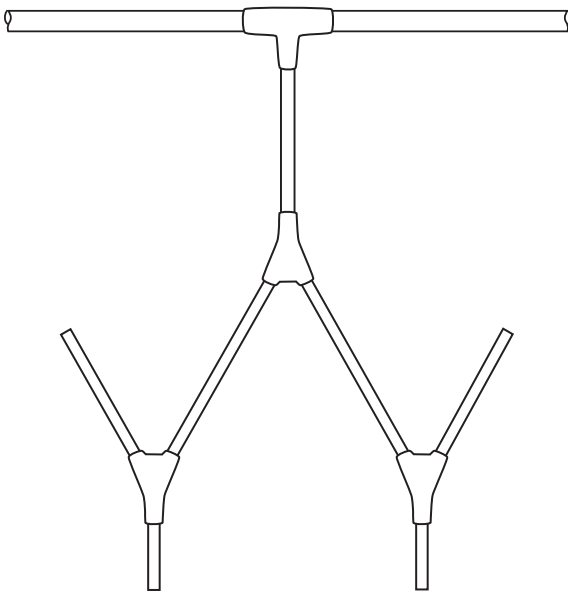

**1 Component**

This example of an assembly made from tubing and barbed fittings is comprised of nine separate pieces of tubing of varying sizes and lengths, plus four fittings that require insertion into the tubing at three points each, with double tie wraps installed at each connection for secure attachment. assembly is necessary.

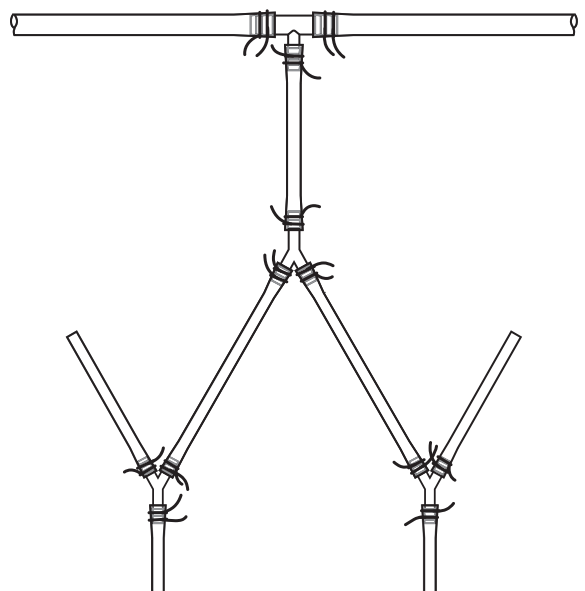

**37 Components**

SILICONE

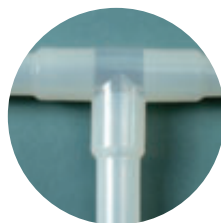

■ Select from a number of different crevice-free connections.



■ Platinum-cured silicone tubing is available from stock in nearly 50 sizes and meets USP Class VI standards. Complete biocompatibility validation packages are available.



Phone: 215-526-2151 Toll Free Phone: 888-755-4370

[www.advantapure.com](http://www.advantapure.com)

■ BioClosure™ container closure systems are manufactured from platinum-cured, Class VI silicone and available solid or with tubing inserts. They can easily become part of your manifold design for batch processing in a variety of sampling and storage containers made from glass, plastics, or metal. Ask a representative for details.



■ Molded mini and standard silicone Tri-Clamp® fittings with protective backing cups may be incorporated into process systems.

Experienced engineers with over 20 years of knowledge in silicone extrusion and molding are available for technical assistance.

SILICONE

■ BioClosure caps, inserts for True Unions and GL45's, and other container closures, available with or without tubing inserts, are also manufactured from platinum-cured, Class VI silicone.



# SINGLE USE MOLDED MANIFOLDS

FOR BATCH FILLING & SAMPLING APPLICATIONS



DocuLink (patent pending) visually identifies each manifold with a part number and/or lot number. The identification is permanently molded into the silicone connector.

Using DocuLink allows easy tracking of a manifold assembly back to its origins. It handles clean-in-place (CIP), steam-in-place (SIP), autoclave, and gamma irradiation processes.

Contact your AdvantaPure sales representative or visit [www.advantapure.com/doculink.htm](http://www.advantapure.com/doculink.htm) for information.

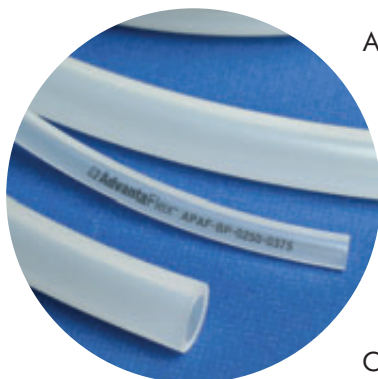

AdvantaFlex addresses the need for a flexible, translucent, heat sealable, and weldable tubing for fluid processing applications.

AdvantaFlex may be attached to single-use biobags and manifolds, and it's sterilizable by autoclave or gamma radiation. Additionally, the unique properties of this special formulation help it outlast other tubing by six-to-ten times in critical stream transfer lines and peristaltic pumps.

AdvantaFlex has been thoroughly tested. A full extractables study is available, along with complete validation documentation.

Contact your AdvantaPure sales representative or visit [www.advantapure.com/advantaflex.htm](http://www.advantapure.com/advantaflex.htm) for information.



## Purity in Fluid Flow Systems®



Made in U.S.A.

Address: NewAge Industries AdvantaPure®  
145 James Way  
Southampton, PA 18966 U.S.A.



DISTRIBUTED BY:

Toll Free Phone: **888-755-4370**  
Phone: **215-526-2151**  
Toll Free Fax: **888-258-4293**  
Fax: **215-526-2167**  
Web Site: **[www.advantapure.com](http://www.advantapure.com)**  
E-mail: **[sales@advantapure.com](mailto:sales@advantapure.com)**

©2011 NewAge® Industries, Inc. Specifications are subject to change without notice. AdvantaPure products are produced by NewAge® Industries, Inc. AdvantaFlex®, BioClosure™, DocuLink™, Purity in Fluid Flow Systems®, NewAge Industries AdvantaPure®, NewAge®, and the "N" logo are trademarks of NewAge® Industries, Inc. Tri-Clamp® registered trademark of Alfa Laval Inc.



WARRANTY: NewAge Industries AdvantaPure products are warranted to be free from defects in material and workmanship. Any product found to carry such defects will be replaced without charge. This warranty is limited only to the replacement of NewAge Industries AdvantaPure products, item for item, which after examination by NewAge Industries AdvantaPure are deemed defective. NewAge Industries AdvantaPure specifically disclaims any other liability. The data supplied is provided as a helpful guideline and is believed to be reliable; however, nothing stated shall constitute a guarantee, recommendation, or warranty for any application.

NOTICE: NewAge Industries, Inc. has been a privately owned corporation since 1954. Neither the corporation nor its principals are affiliated, in any way, with any other group or entity either representing themselves as or being referred to by the term NewAge.